



**Refrigeration
and
Cooling System
Products**

Fiberglass Evaporative Cooling Towers 30 Models from 6 to Over 4,000 GPM

- ◆ Lightweight and compact. Provides quick and easy installation simplified by modular components. Circular designs eliminates prevailing wind issues.
- ◆ Easy access casing simplifies cleaning. Fiberglass panels are bolted using stainless steel hardware. Durable even under the most severe weather conditions.
- ◆ Aerodynamically designed propeller type blades conserve power and assure quiet operation.
- ◆ Water distribution system uses ABS or stainless steel components that require little or no head pressure loss and low maintenance.
- ◆ Non-rusting PVC mesh keeps foreign debris from entering water basin.
- ◆ Heat embossed honeycomb fill provides excellent heat transfer performance and good to 115° F operation.



Dimensions and Pipe Connections

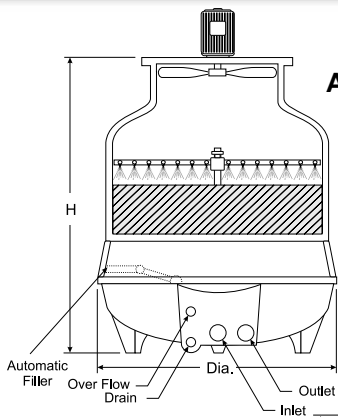

ACT 3-30

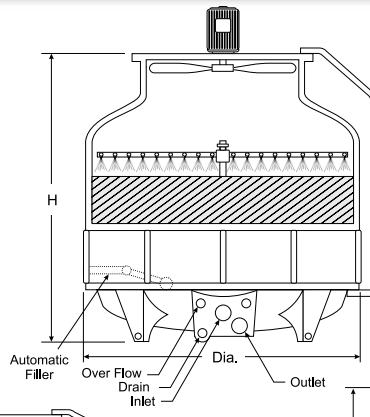

ACT 40-175

Note: Models ACT 3-60 have threaded connections. Models ACT 70-1500 have flanged water in/out connections. All other connections are NPT.

ACT 200-350

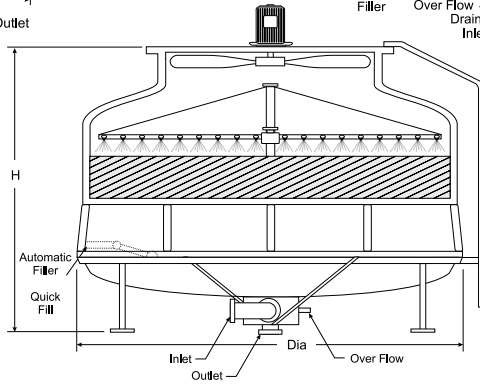

ACT 400-1500

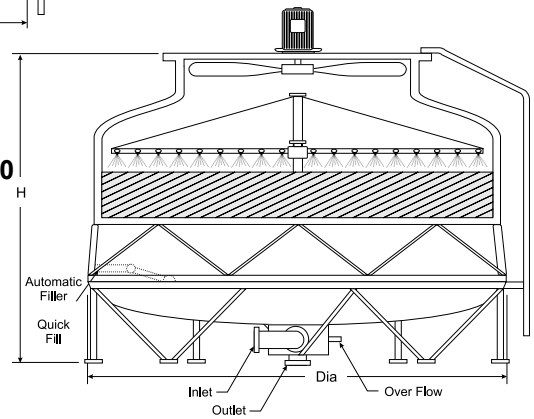

Cooling Tower Model	Outside Dimensions		Pipe Connections						Fan Motor HP	Fan Dia. Inch	Air CFM	Nominal Flow GPM
	Height	Diameter	Inlet	Outlet	Overflow	Drain	Filler	Quickfill				
ACT-3	50	27	1-1/2	1-1/2	1	3/4	1/2	-	1/6	19-1/2	870	6
ACT-5	52	34	1-1/2	1-1/2	1	3/4	1/2	-	1/6	19-1/2	2,100	10
ACT-8	56	34	1-1/2	1-1/2	1	3/4	1/2	-	1/6	19-1/2	2,620	16
ACT-10	54	42	1-1/2	1-1/2	1	3/4	1/2	-	1/4	26-1/2	3,500	20
ACT-15	59	46	2	2	1	1	1/2	-	1/4	26-1/2	4,700	30
ACT-20	63	54	2	2	1	1	1/2	-	1/2	30	6,300	40
ACT-25	71	54	2-1/2	2-1/2	1	1	1/2	-	3/4	30	7,000	50
ACT-30	68	62	2-1/2	2-1/2	1	1	1/2	-	1	30	8,100	61
ACT-40	75	72	2-1/2	2-1/2	1	1	3/4	-	1-1/2	38	9,800	83
ACT-50	75	79	3	3	1	1	3/4	-	1-1/2	38	11,500	105
ACT-60	75	79	3	3	1	1	3/4	-	1-1/2	46	14,700	125
ACT-70	80	86	4	4	1	1	3/4	-	1-1/2	46	17,500	145
ACT-80	80	86	4	4	1	1	3/4	-	2	46	18,900	168
ACT-100	85	105	4	4	1	1	1	-	3	58	24,500	208
ACT-125	87	120	5	5	2	1	1	-	3	58	29,060	262
ACT-150	90	130	5	5	2	2	1	-	5	69	33,260	318
ACT-175	98	130	5	5	2	2	1	-	5	69	40,250	369
ACT-200	118	149	6	6	2	2	1-1/4	1-1/4	5	69	43,760	426
ACT-225	126	149	6	6	2	2	1-1/4	1-1/4	7-1/2	93	61,270	460
ACT-250	126	149	8	8	2	2	1-1/4	1-1/4	7-1/2	93	61,270	520
ACT-300	132	175	8	8	2	2	1-1/4	1-1/4	10	93	77,020	620
ACT-350	134	189	8	8	2	2	1-1/4	1-1/4	10	93	77,020	744
ACT-400	153	204	8	8	4	2	2	2	15	117	91,030	845
ACT-500	155	220	10	10	4	2	2	2	15	117	91,030	1,113
ACT-600	171	260	10	10	4	2	2	2	20	133	125,000	1,278
ACT-700	181	260	10	10	4	2	2	2	20	133	125,000	1,546
ACT-800	194	299	12	12	4	3	2	2	30	141	175,000	1,703
ACT-1000	203	299	12	12	4	3	2	2	30	141	175,000	2,253
ACT-1250	231	332	12	12	4	3	2-1/2	2-1/2	40	168	218,900	2,824
ACT-1500	240	332	14	14	4	3	2-1/2	2-1/2	50	168	264,800	3,380

Nominal Water Flow is defined as rate of water cooled from 95°F to 85°F with a 78°F Wet Bulb Temperature

Specifications subject to change without notice

Concrete Base and Tower Support

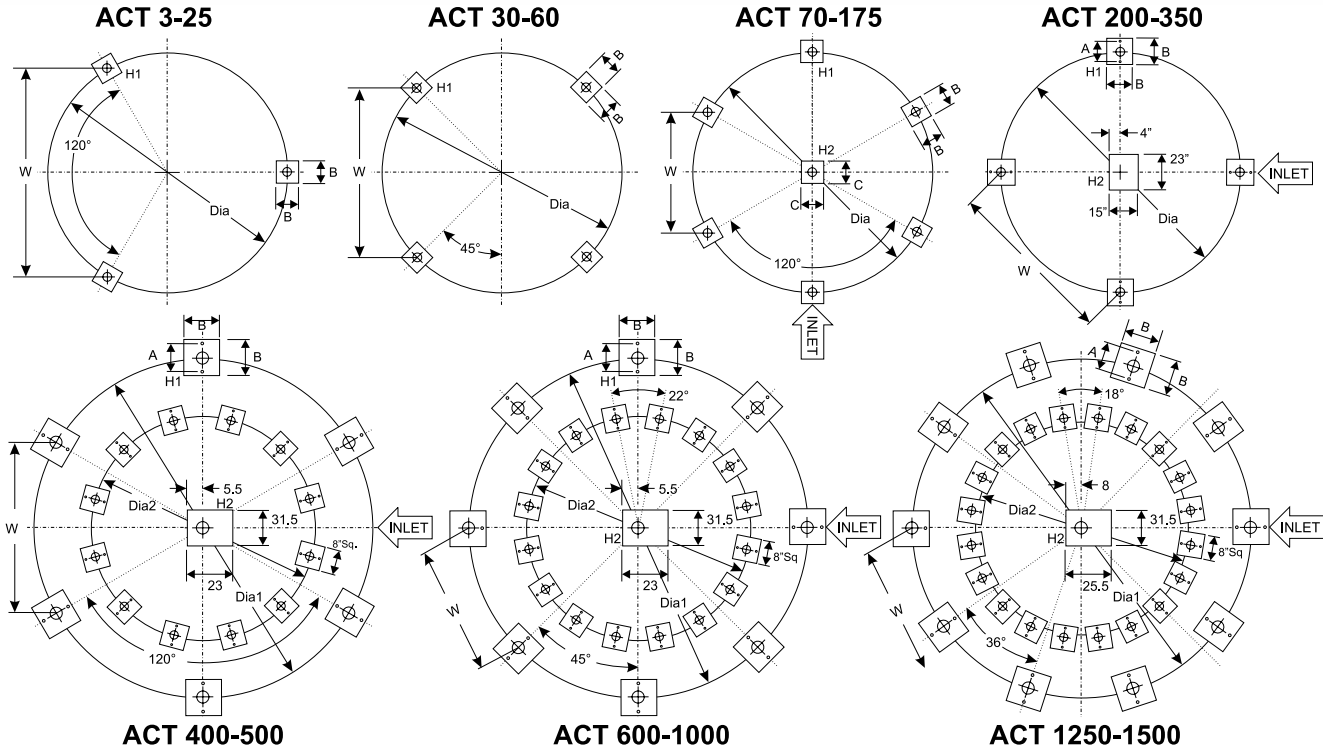

Cooling Tower Model	Weight Lbs		Dimensions Inch								Anchor Bolts			Pump Head
	Dry	Operating	Dia1	Dia2	W	B	A	H1	H2	C	Size	Length	Qty	
ACT-3	62	161	18-1/8	-	15-3/8	8	-	6	-	-	1/2	4-3/4	3	5.0
ACT-5	86	251	21-5/8	-	18-3/4	8	-	6	-	-	1/2	4-3/4	3	5.0
ACT-8	93	262	21-5/8	-	18-3/4	8	-	6	-	-	1/2	4-3/4	3	5.0
ACT-10	123	443	29-1/2	-	25-5/8	8	-	6	-	-	1/2	4-3/4	3	5.0
ACT-15	139	536	34-5/8	-	30	8	-	6	-	-	1/2	4-3/4	3	5.3
ACT-20	190	719	44	-	38-1/4	8	-	6	-	-	1/2	4-3/4	3	5.6
ACT-25	227	887	44	-	38-1/4	8	-	6	-	-	1/2	4-3/4	3	5.6
ACT-30	253	1,074	52-1/2	-	37	8	-	6	-	-	1/2	4-3/4	4	6.0
ACT-40	369	1,133	57-7/8	-	40-7/8	10	-	8	-	-	1/2	4-3/4	4	6.6
ACT-50	435	1,313	66-1/8	-	46-3/4	10	-	8	-	-	1/2	4-3/4	4	6.6
ACT-60	504	1,472	66-1/8	-	46-3/4	10	-	8	-	-	1/2	4-3/4	4	6.6
ACT-70	610	1,555	69-3/8	-	34-1/2	10	-	8	12	10	1/2	4-3/4	5	6.6
ACT-80	642	1,588	69-3/8	-	34-1/2	10	-	8	12	10	1/2	4-3/4	5	6.6
ACT-100	887	2,361	92-1/2	-	46-1/4	12	-	12	14	12	5/8	8	5	8.2
ACT-125	1,025	2,983	103-1/8	-	51-1/2	12	-	12	14	12	5/8	8	5	10.0
ACT-150	1,375	5,731	112-1/2	-	56-1/4	12	-	12	13-1/2	16	5/8	8	5	10.0
ACT-175	1,569	5,887	112-1/2	-	56-1/4	12	-	12	13-1/2	16	5/8	8	5	11.0
ACT-200	1,914	7,612	132	-	93-3/8	12	5-1/8	12	16	23	5/8	8	8	11.0
ACT-225	2,112	7,744	132	-	93-3/8	12	5-1/8	12	16	23	5/8	8	8	12.0
ACT-250	2,266	7,854	132	-	93-3/8	12	5-1/8	12	16	23	5/8	8	8	12.0
ACT-300	2,823	9,995	156-1/8	-	110-3/8	12	5-1/2	12	16	23	5/8	8	8	12.0
ACT-350	2,996	10,164	169-1/8	-	119-5/8	12	5-1/2	12	16	23	5/8	8	8	13.2
ACT-400	4,776	14,984	200-3/4	114-1/2	100-3/8	20	5-1/2	12	16	31-1/2	3/4	8	12	13.2
ACT-500	5,342	15,550	216-1/2	122	108-1/4	20	5-1/2	12	16	31-1/2	3/4	8	12	13.2
ACT-600	7,401	23,637	255-1/8	141-3/4	97-5/8	20	5-1/2	12	16	31-1/2	3/4	8	16	16.4
ACT-700	7,848	24,127	255-1/8	141-3/4	97-5/8	20	5-1/2	12	16	31-1/2	3/4	8	16	18.2
ACT-800	9,636	26,356	295-1/4	163-1/2	113	20	5-1/2	12	16	31-1/2	3/4	8	16	20.0
ACT-1000	10,199	27,359	295-1/4	163-1/2	113	20	5-1/2	12	16	31-1/2	3/4	8	16	20.0
ACT-1250	14,419	57,341	328	168-1/8	101-3/8	20	5-1/2	12	16	31-1/2	3/4	8	20	21.3
ACT-1500	15,400	58,326	328	168-1/8	101-3/8	20	5-1/2	12	16	31-1/2	3/4	8	20	23.0

Cooling Tower Capacities



Cooling Tower Model	Inlet	90°	90°	95°	92°	95°	97°	95°	95°	96°	98°	90°	94°
	Outlet	80°	80°	85°	82°	85°	87°	85°	85°	86°	88°	83°	85°
	Wet Bulb	65°	70°	70°	72°	75°	75°	77°	78°	80°	82°	75°	75°
ACT-3		9	6	9	7	8	9	6	6	5	6	8	9
ACT-5		15	10	15	11	12	15	10	10	9	10	13	14
ACT-8		24	18	24	19	20	24	18	16	14	15	22	23
ACT-10		30	21	30	23	26	30	21	20	18	20	28	29
ACT-15		46	33	47	30	40	47	33	30	28	30	41	43
ACT-20		61	44	62	48	52	62	44	40	37	40	56	58
ACT-25		77	56	78	60	66	78	56	50	47	50	70	72
ACT-30		91	68	93	72	80	93	68	61	57	61	84	87
ACT-40		122	90	124	97	107	124	91	83	77	82	112	116
ACT-50		152	114	156	121	134	156	115	105	98	104	140	145
ACT-60		183	137	187	146	160	187	137	125	116	124	169	174
ACT-70		214	160	218	170	187	218	160	145	135	144	197	203
ACT-80		244	183	250	195	214	250	183	168	156	167	225	232
ACT-100		306	228	311	243	268	311	229	208	193	207	281	290
ACT-125	FLOW RATE	381	287	390	305	335	390	288	262	245	261	352	362
ACT-150	GPM	456	346	468	368	403	468	348	318	297	318	422	435
ACT-175		533	401	546	428	470	546	403	369	344	367	493	508
ACT-200		608	461	624	490	539	624	464	426	398	425	563	580
ACT-225		691	509	702	543	600	702	508	460	427	457	633	652
ACT-250		765	570	780	608	670	780	571	520	484	518	704	725
ACT-300		920	681	936	727	801	936	682	620	575	616	845	871
ACT-350		1065	808	1092	859	942	1092	812	744	695	742	986	1016
ACT-400		1220	920	1249	979	1075	1249	924	845	788	842	1127	1161
ACT-500		1502	1182	1560	1250	1363	1560	1200	1113	1053	1119	1408	1453
ACT-600		1825	1386	1873	1473	1616	1873	1394	1278	1194	1275	1690	1742
ACT-700		2108	1648	2185	1745	1904	2185	1670	1546	1459	1551	1971	2035
ACT-800		2433	1848	2498	1965	2155	2498	1860	1703	1592	1700	2255	2323
ACT-1000		2994	2379	3121	2514	2735	3121	2421	2253	2139	2270	2815	2908
ACT-1250		3740	2977	3902	3146	3421	3902	3032	2824	2683	2846	3519	3635
ACT-1500		4491	3568	4683	3771	4102	4683	3632	3380	3209	3404	4223	4361

Nominal Water Flow is defined as rate of water cooled from 95°F to 85°F with a 78°F Wet Bulb Temperature
 ArctiChill also has steel cooling towers available from major manufacturers to meet specific requirements.
 Consult the factory for Free-Cooling Systems using cooling towers, plate heat exchangers and pumping systems.

Represented By:

ArctiChill
 200 Park Avenue
 Newberry, SC 29108
 Toll-Free: (800) 849-7778
 Phone: (803) 321-1891
 Fax: (803) 321-1898
www.arctichill.com